

DUAL GPR 120/240V w/SST Fnl, 3 Settings

Height: 29.3" Width: 18.0" Depth: 22.2"
(74.4cm) (45.7cm) (56.4cm)

- Each 1.5GPR portable server (included) has a Safety-Fresh® brew-through lid with vapor seal and spill protection
- Adjustable bypass ensures perfect coffee regardless of batch size
- Brews 1/2, 1 or 1 1/2gal (1.9, 3.8 or 5.7L) batches
- SplashGard® funnels deflect hot liquids away from the hand



Agency:



Specifications

Product #: 20900.0011

Funnel: Stainless Steel

Water Access: Plumbed

Faucet: Upper

Interface: Cabled

Finish: Stainless

Additional Features

Electrical & Capacity

Volts*	Amps	Watts	Cord Attached	Plug Type	8oz cups/hr 236ml cups/hr	Input H ₂ O Temp.	Phase	# Wires plus Ground	Hertz
120/240	28.7	6890	No	-	309	60°F (15.5°C)	1	3	60

*When a BUNN is machine rated 120/208-240V, 120/208V or 120/240V, the higher voltage is the supply voltage needed to power the machine. The 120V is there to supply power to some components rated 120V in the machine, but it is not the supply voltage and would not power the machine if the machine is marked with the before mentioned ratings.

Plumbing Requirements

PSI	kPa	Fitting Supplied	Water Flow Required (GPM)
20-90	138-621	1/4" Male Flare Fitting	-

CAD Drawings

2D	Revit	KLC
●		

WARNING:



BUNN® reserves the right to change specifications and product design without notice. Such revisions do not entitle the buyer to corresponding changes, improvements, additions or replacements for previously purchased equipment. For most current specifications and other info visit bunn.com.

Last Updated:
02/24/2026

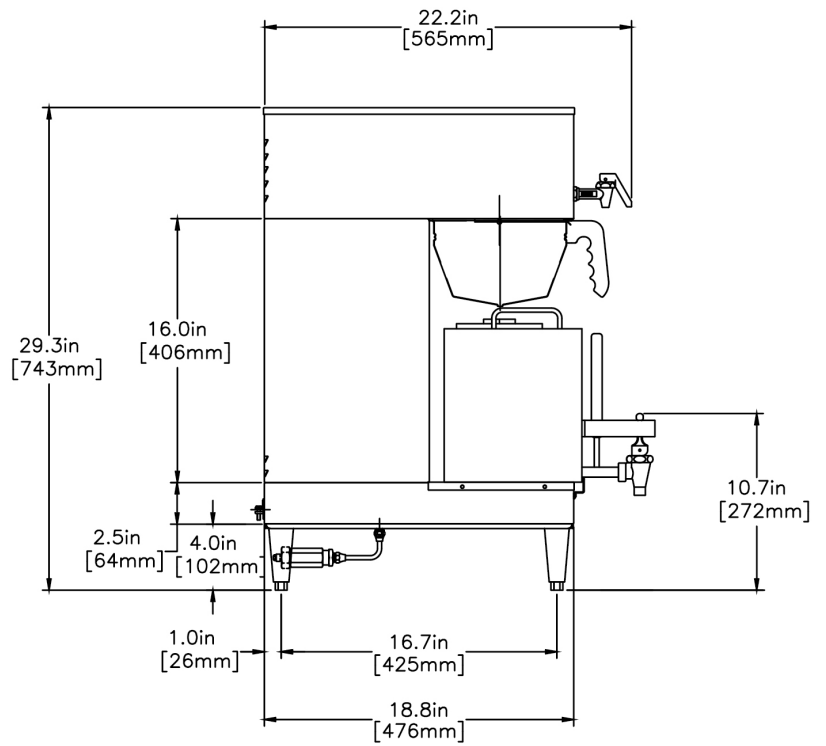
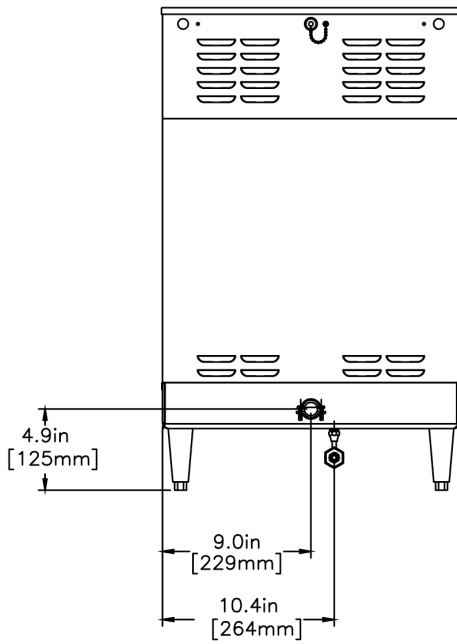
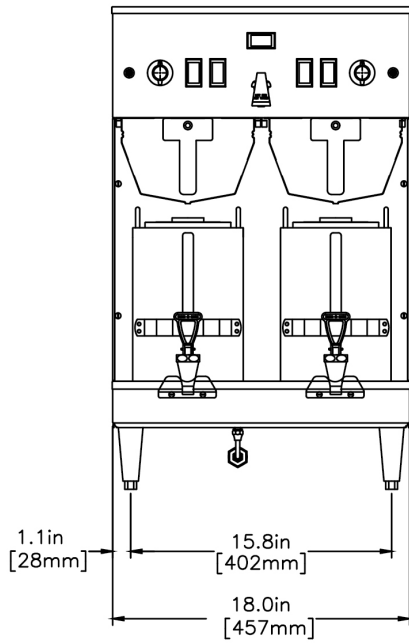

	Unit			Shipping				
	Height	Width	Depth	Height	Width	Depth	Weight	Volume
English	29.3 in.	18.0 in.	22.2 in.	33.9 in.	21.4 in.	29.9 in.	95.350 lbs	12.518 ft ³
Metric	74.4 cm	45.7 cm	56.4 cm	86.0 cm	54.3 cm	75.9 cm	43.251 kgs	0.354 m ³



BUNN® reserves the right to change specifications and product design without notice. Such revisions do not entitle the buyer to corresponding changes, improvements, additions or replacements for previously purchased equipment. For most current specifications and other info visit bunn.com.

Last Updated:
02/24/2026

Related Products & Accessories: DUAL GPR 120/240V w/SST Fnl, 3 Settings(20900.0011)



RWS1, 120V

Product #: 12203.0010¹



FUNNEL ASSY, SST
(DUAL/SGL)

Product #: 20201.1201²

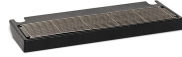

DRIP TRAY KIT, DUAL &
SH

Product #: 27150.0000



POUCHPACK FUNL
ASSY, COFFEE BL

Product #: 35282.0000²



WATER FILTER,
EQHP-10L

Product #: 39000.0001³



SYSTEM, WQ-55(2)5L

Product #: 56000.0001¹



SYSTEM, WEQ-10(1.5)5L

Product #: 56000.0024¹



CARTRIDGE, WQ-55(2)5L

Product #: 56000.0101¹



CARTRIDGE, WEQ-10
(1.5)5L

Product #: 56000.0121¹

¹NSF Certified ²NSF Certified with spec sheet model listed ³NSF Certified under Solventum Purification ⁴NSF Certified under Mavea LLC ⁵NSF Certified under Zojirushi ⁶NSF Certified under Qins Inc ⁷NSF COMPONENT Certified



BUNN® reserves the right to change specifications and product design without notice. Such revisions do not entitle the buyer to corresponding changes, improvements, additions or replacements for previously purchased equipment. For most current specifications and other info visit bunn.com.

Last Updated:
02/24/2026

Serving & Holding Options: DUAL GPR 120/240V w/SST Fnl, 3 Settings(20900.0011)



RWS1, 120V

Product #: 12203.0010¹



1.5GPR-FF, TOP HNDL

Product #: 20950.0004¹

¹NSF Certified ²NSF Certified with spec sheet model listed ³NSF Certified under Solventum Purification ⁴NSF Certified under Mavea LLC ⁵NSF Certified under Zojirushi ⁶NSF Certified under Qins Inc ⁷NSF COMPONENT Certified



BUNN® reserves the right to change specifications and product design without notice. Such revisions do not entitle the buyer to corresponding changes, improvements, additions or replacements for previously purchased equipment. For most current specifications and other info visit bunn.com.

Last Updated:
02/24/2026