

CHESTNUT S3

Everything just clicks.



Built around our custom S2C890 burrs, Chestnut S3 is all about precision. From the lens-like external adjustment ring to our new drop-out burr system, Chestnut S3 brings new clarity and complexity to your coffee.



Lens-style Adjustment Ring

Enables smooth and accurate grind selection.

S2C890 Burr Set

Hexagonal clarity-driven design.

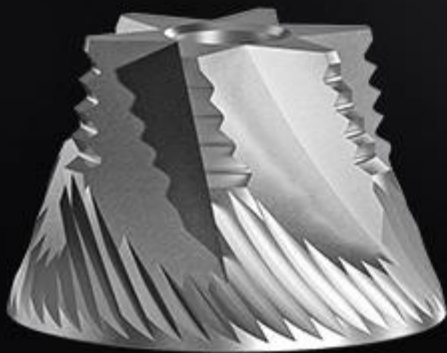

15 Microns per Click

Dial in like never before.

Pull-to-fold Handle

Collapsible for maximum portability.

Custom-designed bearings

Improves grind selection accuracy by **20%**.



Embrace your daily grind.

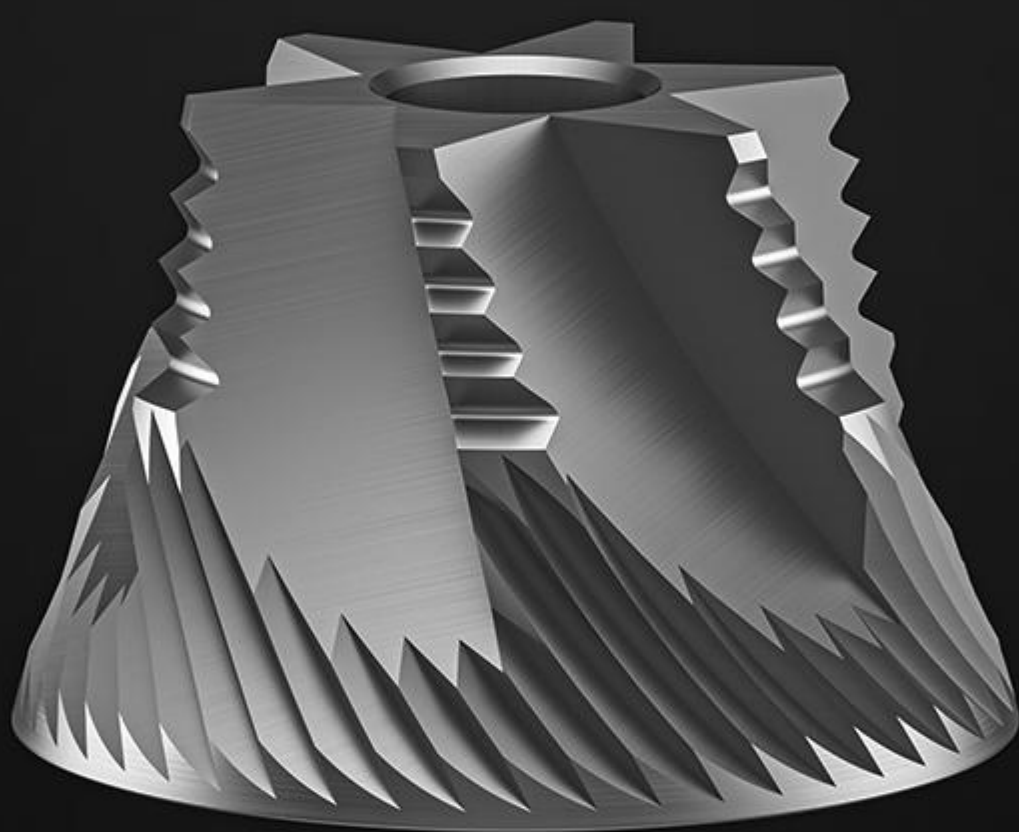

In pursuit of the perfect pour-over, we meticulously redesigned the cutting surfaces of our 42 mm café-quality burr set. Our relentless refinements bring effortless grinding and exceptional flavor clarity, making the S2C890 one of our best burr sets ever.

Groundbreaking refinements.

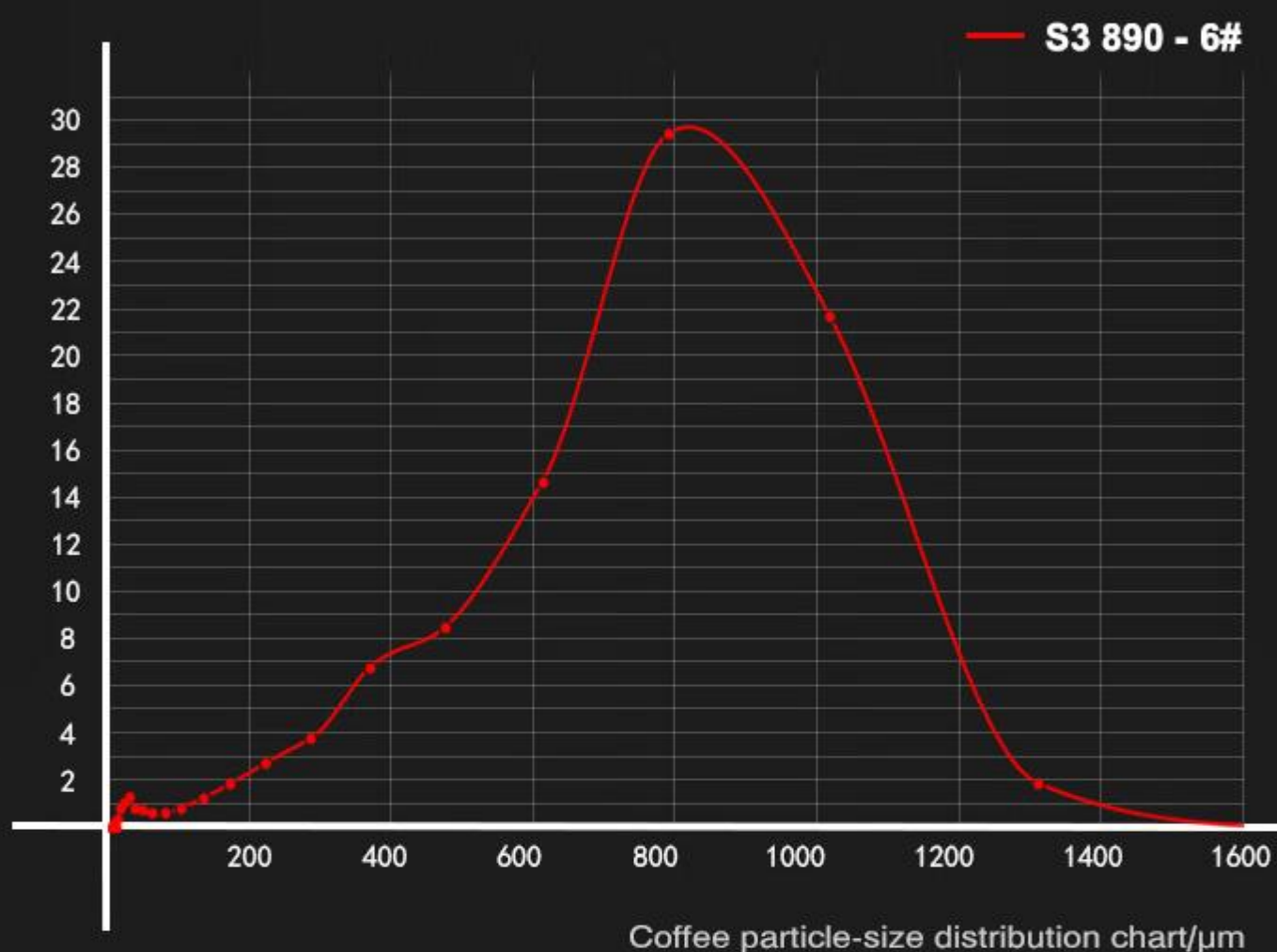

Not all grounds are created equal.

We designed S2C890 to reduce fines in the 200-250 µm range, while increasing the proportion of fines in the 250-400 µm range, peaking at around 375 µm. These adjustments significantly enhance cup quality, resulting in improved clarity and sweetness.

Engineered to endure.



SUS420

Hardened Stainless Steel









5-Axis CNC

Manufacturing Process



58 HRC

Industry Standard Sharpness

	S2C890	S2C880	S2C660
 Burr Model	S2C890	S2C880	S2C660
 Featured Grinders	S3	Xlite	C3S
 Burr Diameter	42 mm	42 mm	38 mm
 Adjustment Precision	15 μ m per click 90 clicks per revolution	83 μ m per click 48 clicks per revolution	83 μ m per click 12 clicks per revolution
 Tasting Notes	Brings great flavor separation while maintaining sweetness.	Brews full-bodied, well-integrated coffee.	Superb texture and body for rich brewed flavor.
 Recommended Coffee Profile	● ● ● Light to medium roast	● ● ● Medium to dark roast	● ● ● Medium to dark roast
 Optimal Brew Method	Pour-over	Pour-over	Pour-over

*Though optimized for Pour-over, these grinders specified in this comparison chart are also capable of grinding for everything from Espresso to French Press

Flavor focused.

Sometimes it's what's on the outside that counts. S3 brings TIMEMORE's first-ever external grind adjustment ring, allowing you to quickly dial in picture-perfect brews.



Step things up — or down.

Make minute adjustments with just 15 microns of travel between grind settings.



S3 offers 90 grind settings in a single rotation, letting you go from Espresso to French Press with just a twist of the wrist.



Espresso

1-15 clicks



Moka

5-20 clicks



Pour-over

50-80 clicks



French Press

80-90 clicks

More than a shot in the dark.

The S3 isn't just an all-rounder; it's a master of versatility. From bold, smooth espresso with rich conical sweetness to flawlessly balanced pour-overs, S3 lets you experience your coffee like never before.



**Goodbye
guesswork.**

Ultra-low clearance
bearings

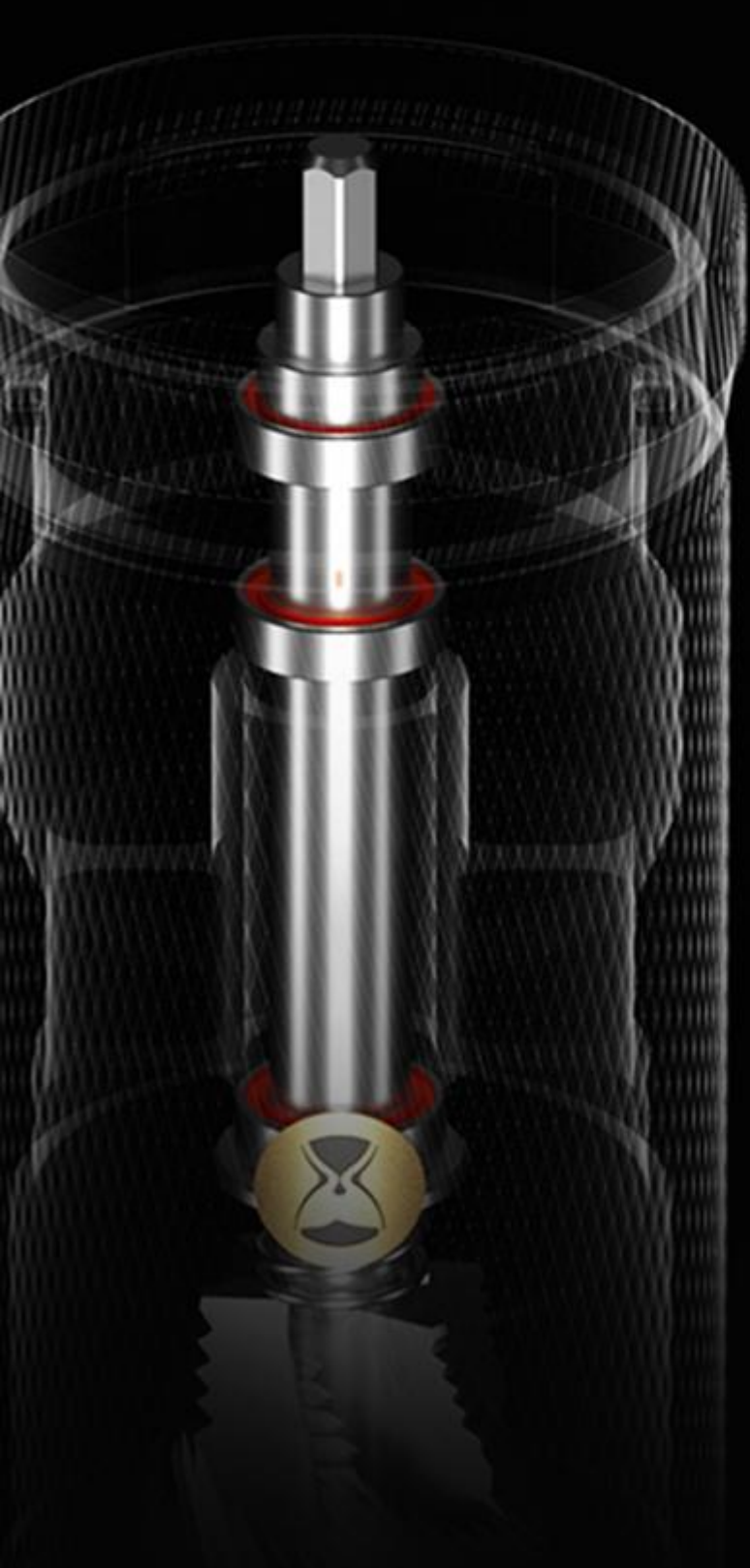

S3 introduces our first ever fully custom bearing system, decreasing tolerances by **20%** for improved grind consistency.

Fine, finer, finest.

Precision aligned burrset

A close-up photograph of the grinding mechanism of a Chestnut S3 tool. The image shows a circular grinding wheel with a blue-tinted rim. A white rectangular label is attached to the center of the wheel, featuring a lock icon, a curved arrow, and the text "KEEP LOCKED". A white line points from the text "Precision aligned burrset" to the gap between the grinding wheel and the tool's body.

Each Chestnut S3 leaves the factory with a burr gap of just **0.075 mm***, a tolerance which is smaller than the width of a human hair.

*At the finest grind setting (0 clicks), the S3's burr gap is precisely alligned to 0.075 mm to account for manufacturing tolerances. When grinding at the finest setting, pressing down on the handle may cause the shaft to shift slightly, potentially causing minor burr rub.

Peak precision.

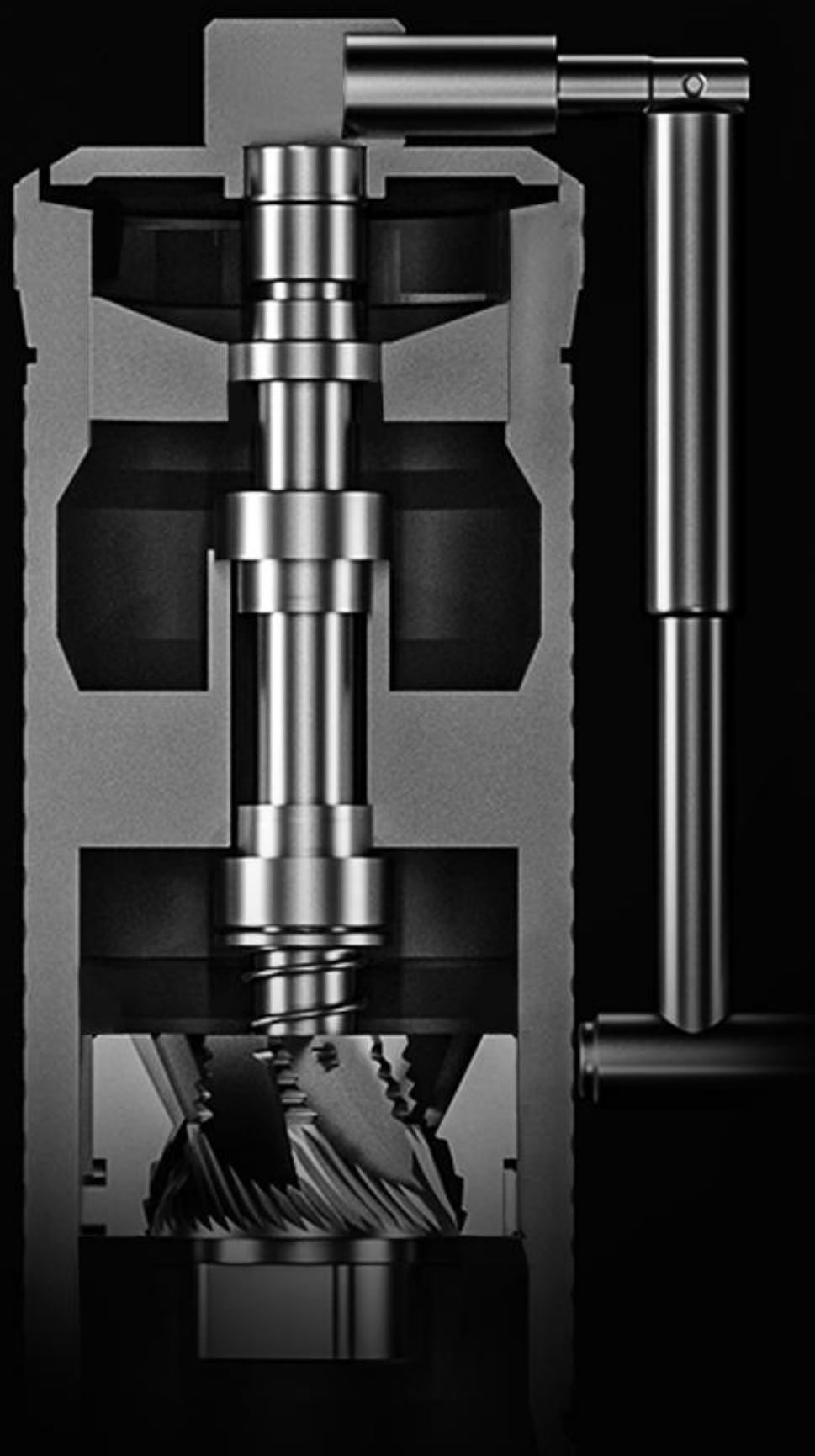

A triumph of engineering, Chestnut S3 brings smaller tolerances, allowing for all-metal components.

Inside out innovation.



Our drop-out burr system allows the internal grinder assembly to slide out, making cleaning and maintenance a breeze.

Subtle but significant.

Our latest Chestnut brings a host of quality-of-life improvements, making S3 one of our best grinders ever.



Pull-to-fold handle

patent NO.: ZL201720292267.1



**Non-slip
silicone base**

Easy-grip grooves
and durable
all-metal
construction



Product Specifications



NAME:

Chestnut S3 Coffee Grinder

COLORS:

Matt Black / Olive Green / Red

CAPACITY:

Max: 30 g

MATERIALS:

Aluminum Alloy + Stainless Steel + Silicone

SIZE:

Body: 182.1 mm x 55 mm

Handle: 163 mm (fully extended)

Cleaning Tip: skip the suds – use only a brush to clean your grinder.

**Bring competition-tier
flavor everywhere you go.**



Get the real deal.

To ensure that you receive an authentic TIMEMORE product, always purchase directly from us or through one of our authorized distributors. Copies can be hard to spot, so we've introduced a unique code to verify the authenticity of your purchase.



>

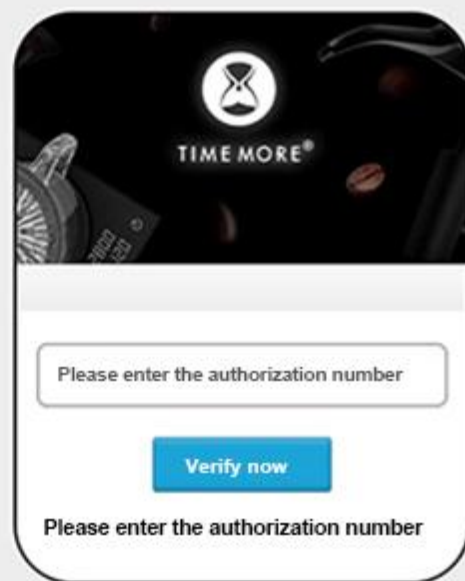

▲ Scratch off the coating and scan the QR code.

▲ Enter your unique code to verify authenticity.

Q&A

We sat down with our Shanghai design team to learn what inspired them to create Chestnut S3, as well as how it compares to other products in our range.

Q: What are the flavor characteristics the Chestnut S3 produces?

A: We have long been advocates for keeping things sweet and clean. This philosophy has been honed over a decade of collaboration and feedback with coffee professionals and home users alike. With Chestnut S3, we spent hundreds of hours chasing high uniformity coffee particles. The result is a balanced cup, bringing good flavor separation and a lasting, clean finish.

Q: So how does Chestnut S3 compare to something like the Xlite grinder?

A: That's actually a great point of comparison. The Xlite features one of our earlier burr sets. S3's burr set is kind of a balancing act -- we tried to optimize our burr set for cupping at 800 μm . In doing so, we refined the production of particles between 250-400 μm . Our team found that these tweaks really boosted sweetness and complexity.

Q: Is Chestnut S3 an upgrade over the Chestnut C3?

A: We'd like to think so. In our opinion, the S3 brings huge improvements in cup, along with our first ever external grind adjustment ring. Our grind step threshold was 15 μm — if travel between settings was any bigger, we decided we wouldn't introduce the feature. It took a lot of back and forth with our factory, but we got there in the end.

Q: How did your team decide which features to introduce to the S3?

A: Believe it or not, we read every email that comes in and basically every forum post about our products. Sometimes we enter the design phase knowing what we want, other times we learn from our users. This time, the features sought by our team and our users were pretty much unanimous. The S3 brings a brand new burr set, external adjustment, and an easier way to access the burrs. We're really thrilled with how it came out.

Terms and Conditions Summary

To keep your grinder working optimally for many years to come, follow these five easy suggestions:

1. This device is for grinding roasted coffee beans only. Seriously, that's it.
2. Clean with a brush; do not wash with water.
3. Avoid disassembling the grinder or replacing any parts yourself. If you decide to tempt fate, handle your grinder with care; the metal burrs are sharp.
4. Keep out of reach of children. They're too young to develop a coffee habit.
5. Store in a cool, dry place.

Finally, remember that once used to grind coffee beans, your grinder is non-refundable and can't be returned unless there's a quality or manufacturing issue. TIMEMORE reserves the right to accept service requests on a case by case basis.